

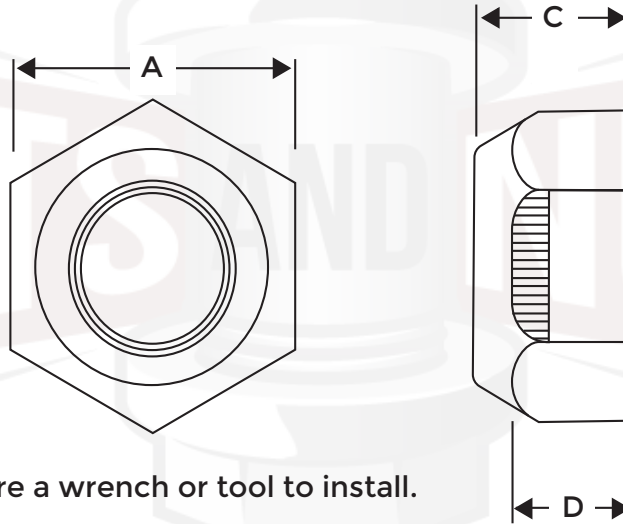

Grade C Hex Lock Nuts



This nut will require a wrench or tool to install.

Nominal Size or Basic Bolt Diameter	A		C		D
	Width Across Flats		Nut Thickness		Hex Height
	Max	Min	Max	Min	Min
1/4"	.439	.430	.328	.298	.225
5/16"	.502	.489	.359	.329	.250
3/8"	.564	.551	.468	.438	.335
7/16"	.627	.616	.468	.438	.324
1/2"	.752	.736	.609	.579	.464
9/16"	.877	.861	.656	.626	.469
5/8"	.940	.922	.765	.735	.593
3/4"	1.064	1.052	.890	.860	.742
7/8"	1.252	1.239	.999	.969	.790
1"	1.440	1.427	1.078	1.016	.825

Dimensions: IFI-100/107
Material: Grade C (Grade 8 Equivalent)
Threading: ASME B1.1, UNC & UNF, Class 2B
All Metal Locking Feature:
 Top is pressed or crimped to displace threads which creates the locking feature.

440.606.6557

www.boltsandnuts.com

info@boltsandnuts.com

ONLINE FASTENER GROUP LLC CLAIMS ALL PROPRIETARY RIGHTS TO THIS DRAWING AND THE INFORMATION IT CONTAINS. THIS MATERIAL IS CONFIDENTIAL. DISCLOSURE, REPRODUCTION, AND MANUFACTURING IS STRICTLY PROHIBITED WITHOUT THE EXPRESS WRITTEN PERMISSION OF ONLINE FASTENER GROUP LLC . ALL RIGHTS OF DESIGN OR INVENTION ARE RESERVED.