

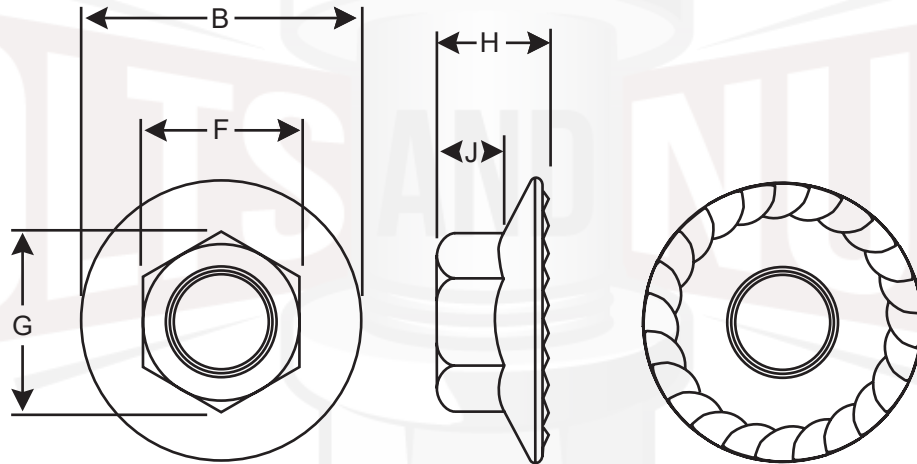

Case Hard Serrated Large Flange Nuts



Inches									
Nominal Size or Basic Bolt Diameter	F		G		B		H		J
	Width Across Flats		Width Across Corners		Flange Dia		Nut Thickness		Wrench Height
	Max	Min	Max	Min	Max	Min	Max	Min	Min
1/4	0.438	0.428	0.505	0.488	0.728	0.700	0.312	0.281	0.15
5/16	0.500	0.489	0.577	0.557	0.820	0.790	0.375	0.343	0.20
3/8	0.562	0.551	0.650	0.628	0.915	0.885	0.406	0.390	0.24
1/2	0.750	0.736	0.866	0.840	1.205	1.175	0.515	0.485	0.29
Dimensions: Large Flange IFI-145 or ASME B18.2.2 with 24 Locking Serrations Material: Case Hardened Low Carbon Steel									

440.606.6557

www.boltsandnuts.com

info@boltsandnuts.com

ONLINE FASTENER GROUP LLC CLAIMS ALL PROPRIETARY RIGHTS TO THIS DRAWING AND THE INFORMATION IT CONTAINS. THIS MATERIAL IS CONFIDENTIAL. DISCLOSURE, REPRODUCTION, AND MANUFACTURING IS STRICTLY PROHIBITED WITHOUT THE EXPRESS WRITTEN PERMISSION OF ONLINE FASTENER GROUP LLC . ALL RIGHTS OF DESIGN OR INVENTION ARE RESERVED.