

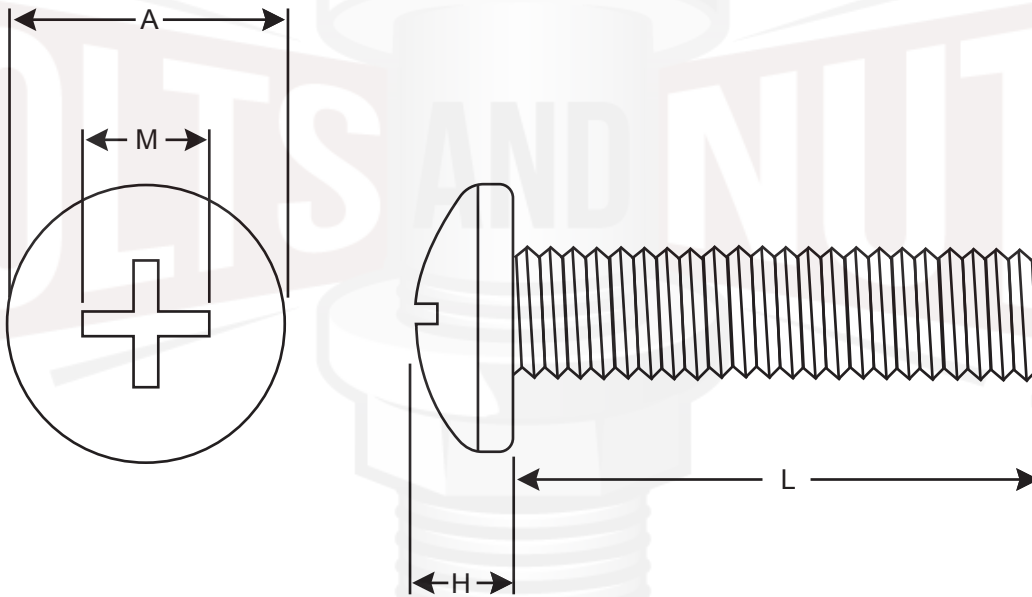

## Phillips Pan Head Machine Screws



Nominal Size or Basic Bolt Diameter	A		H		M
	Head Diameter		Height of Head		Recess Diameter
	Max	Min	Max	Min	Ref.
#6	0.270	0.256	0.097	0.087	0.159
#8	0.322	0.306	0.115	0.105	0.175
#10	0.373	0.357	0.133	0.122	0.192

**Dimensions: ASME B18.6.3 - Full Thread**  
**Material: Low Carbon Steel**  
**Threading: ASME B1.1, UNC & UNF, Class 2A**

440.606.6557

www.boltsandnuts.com

info@boltsandnuts.com

ONLINE FASTENER GROUP LLC CLAIMS ALL PROPRIETARY RIGHTS TO THIS DRAWING AND THE INFORMATION IT CONTAINS. THIS MATERIAL IS CONFIDENTIAL. DISCLOSURE, REPRODUCTION, AND MANUFACTURING IS STRICTLY PROHIBITED WITHOUT THE EXPRESS WRITTEN PERMISSION OF ONLINE FASTENER GROUP LLC . ALL RIGHTS OF DESIGN OR INVENTION ARE RESERVED.